



COUNTERTOP GAS OPEN BURNER RANGES



Job _____ Item # _____

GAS COUNTER TOP OPEN BURNER RANGES



Model XOB-848

- Model XOB-212
- Model XOB-424
- Model XOB-636
- Model XOB-848

SPECIFICATIONS

Gas counter top open burner ranges with a low profile design are only 13 1/4" tall to range surface making them ideal for use on refrigerated cabinets or countertops.

XOB Series Ranges are designed to mix and match with the XX Series Char Broilers and XG Series Counter Top Griddles.

The XOB open burner counter top ranges feature exceptionally heavy, removable, individual cast iron top grates. Four widths are available including a 12" wide (305mm) two-burner, 24" wide (610mm) four-burner, 36" wide (915mm) six-burner and a 48" wide (1220mm) eight-burner.

The XOB Series features two high-performance, cast iron, 30,000 BTUH burners located every 12" with lift-off burner heads for easy cleaning and with individual, operator-controlled valves.

The interior combustion chamber is heavy-duty heat resistant 11- and 16-gauge steel, and is hand-welded for strength and durability.

Standard features include all stainless steel exterior, stainless steel landing ledge, stainless steel back-splash and large capacity, slide-out stainless steel crumb tray.

Additional features include individual 3/4" NPT rear gas connection in natural or LP gas, pressure regulator and 4" (102mm) NSF approved legs with adjustable bullet feet.

One year limited parts and labor warranty.

STANDARD FEATURES

- 28 1/2" deep range top
- Heavy gauge, hand-welded, heat-resistant steel combustion chamber
- 30,000 BTUH burners - two per every 12"
- Up to 240,000 total BTUH in natural or LP gas
- Individually operated burner valves
- Stainless steel back-splash
- All stainless steel exterior
- Stainless steel landing ledge
- Low profile, counter top design - only 13 1/4" to range surface
- Stainless steel, slide-out crumb tray
- Heavy-duty 4" NSF approved chrome legs with adjustable bullet feet
- 3/4" (19mm) NPT rear gas connection
- Limited one year parts & labor warranty

OPTIONS & ACCESSORIES

- Stainless steel front-mounted work deck with or without sauce pan cut-outs
- Gas connector hoses
- Equipment stands with or without casters

CERTIFICATIONS



BAKERS PRIDE OVEN COMPANY, INC.
30 Pine Street, New Rochelle, NY 10801
914/576-0200 • 1-800-431-2745 • fax 914/576-0605
www.bakerspride.com

Continuous product improvement is a policy of Bakers Pride Oven Company. Therefore, specifications and design are subject to change without notification

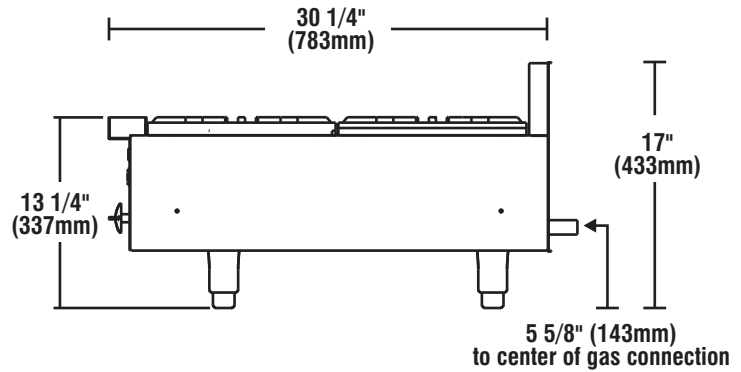
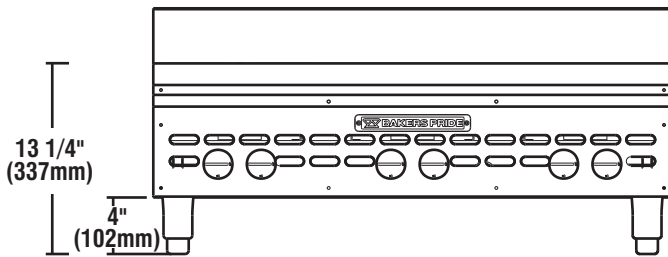
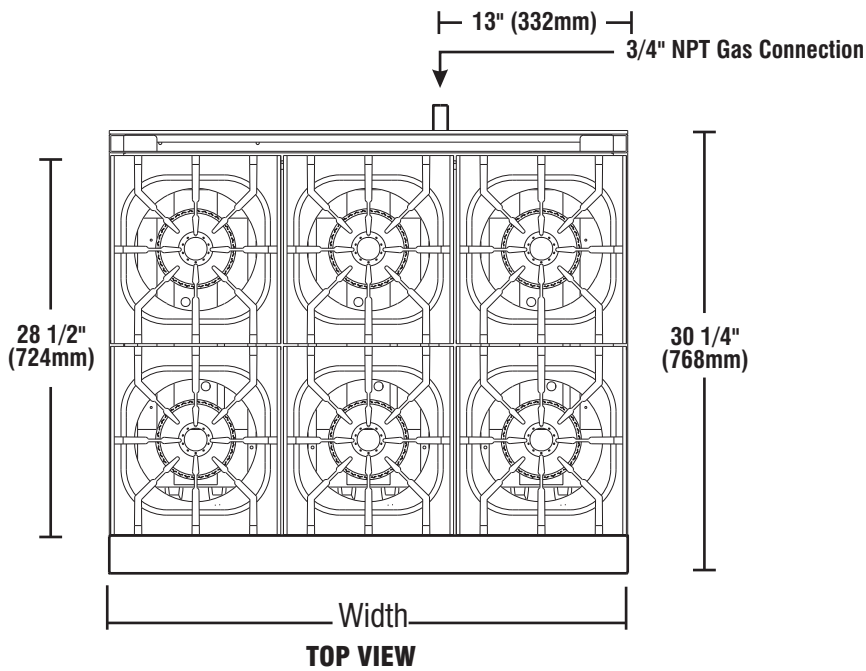

ALL DIMENSIONS NOMINAL

SHIPPING INFORMATION

Model	Shipping Weight		Carton Dimensions						Cubic	
	Lbs.	Kilos	Width		Depth		Height		Feet	Meter
			Inches	mm	Inches	mm	Inches	mm		
XOB-212	250	114	32	813	24	610	24	610	10.6	.31
XOB-424	320	145	32	813	36	914	24	610	16	.46
XOB-636	400	182	34	864	52	1321	24	610	24.6	.71
XOB-848	540	245	34	864	64	1626	24	610	30.2	.88

GAS SUPPLY

Model	BTUH	KW	CONNECTION
XOB-212	60,000	17.57	3/4"
XOB-424	120,000	35.15	3/4"
XOB-636	180,000	52.72	3/4"
XOB-848	240,000	70.30	3/4"

SPECIFICATIONS

Model	Range Top Area		# of Burners	Overall Dimensions*					
	in.	mm		Width		Depth		Height	
				Inches	mm	Inches	mm	Inches	mm
XOB-212	12x28 1/2	305x724	2	12	305	30 1/4	768	13 1/4	337
XOB-424	24x28 1/2	610x724	4	24	610	30 1/4	768	13 1/4	337
XOB-636	36x28 1/2	914x724	6	36	914	30 1/4	768	13 1/4	337
XOB-848	48x28 1/2	1219x724	8	48	1219	30 1/4	768	13 1/4	337

*Height includes 4" (102 mm) standard legs to range surface

MINIMUM CLEARANCES

	Non-combustible construction only	
	Inches	mm
Right	0	0
Left	0	0
Rear	0	0

• From non-combustible construction
• Install only with non-combustible material above range top



BAKERS PRIDE OVEN COMPANY, INC.
30 Pine Street, New Rochelle, NY 10801
914/576-0200 • 1-800-431-2745 • fax 914/576-0605
www.bakerspride.com

Continuous product improvement is a policy of Bakers Pride Oven Company. Therefore, specifications and design are subject to change without notification

COOKLINE-XOB — TSW:05/08